

Modular Cooking Range Line thermaline 85 - Half Module Electric Fry Top, 1 Side with Backsplash

ITEM # _____

MODEL # _____

NAME # _____

SIS # _____

AIA # _____



588530 (MBHMBBDOAO) Electric fry top with smooth chrome plate, one-side operated with backsplash

588534 (MBHNBBDOAO) Electric fry top with ribbed chrome plate, one-side operated with backsplash

Short Form Specification

Item No. _____

Unit constructed according to DIN 18860_2 with 20 mm drop nose top. Internal frame for heavy duty sturdiness in 2 mm and 3 mm in 1.4301 (AISI 304). 2 mm top in 1.4301 (AISI 304). Flat surface construction, easily cleanable. THERMODUL connection system enables seamless worktop when units are connected and avoids soil penetrating. Smooth chromium-plated mild steel cooking surface with non-stick finishing for optimal grilling. Stainless steel high splash guards on the rear and sides. Powerblock heating system for optimal temperature distribution. Large drain hole allows draining of cooking juices into a large collector. Overheat protection switches off the supply in case of overheating. Standby function saves energy and quickly recovers maximum power. Metal knobs with embedded hygienic silicon "soft" grip enable easier handling and cleaning. IPX5 water resistant certification.

Configuration: One side operated top with backsplash. The base needs to be supplied by the factory. Please include appropriate base.

Main Features

- Stainless steel high splash guards on the rear and sides of cooking surface.
- Large drain hole on cooking surface permits the draining of residual cooking juices into a large collector placed under the cooking surface.
- Powerblock heating system for optimal temperature distribution.
- Metal knobs with embedded hygienic "soft-touch" grip for easier handling and cleaning. The special design of the controls prevents infiltration of liquids or soil into vital components.
- Units have separate controls for each half module of the cooking surface.
- THERMODUL connection system creates a seamless work top when units are connected to each other thus avoiding soil penetrating vital components and facilitating the removal of units in case of replacement or service.
- Overheat protection: a temperature sensor switches off the supply in case of overheating.
- All major components may be easily accessed from the front.

Construction

- 2 mm top in 1.4301 (AISI 304).
- Flat surface construction with minimal hidden areas to easily clean all surfaces
- Internal frame for heavy duty sturdiness in 1.4301 (AISI 304).
- Cooking surface in chromium-plated mild steel with non-stick finishing for optimum grilling results.
- Unit constructed according to DIN 18860_2 with 20 mm drop nose top.
- Cooking surface to be completely smooth or completely ribbed.
- Unit constructed according to DIN 18860_2 with 20 mm drop nose top and 70 mm recessed plinth. (only for 588534)
- IPX5 water resistance certification.

Sustainability

- Standby function for energy saving and fast recovery of maximum power.

APPROVAL: _____

Optional Accessories

- Connecting rail kit for appliances with backsplash, 850mm PNC 912498
- Portioning shelf, 400mm width PNC 912522
- Portioning shelf, 400mm width PNC 912552
- Folding shelf, 300x850mm PNC 912579
- Folding shelf, 400x850mm PNC 912580
- Fixed side shelf, 200x850mm PNC 912586
- Fixed side shelf, 300x850mm PNC 912587
- Fixed side shelf, 400x850mm PNC 912588
- Back panel, 400x700mm, for tops and units with backsplash PNC 913009
- Endrail kit, flush-fitting, with backsplash, left PNC 913115
- Endrail kit, flush-fitting, with backsplash, right PNC 913116
- Scraper for smooth plates (only for 588530) PNC 913119
- Scraper for ribbed plates (only for 588534) PNC 913120
- Endrail kit (12mm) for thermaline 85 units with backsplash, left PNC 913206
- Endrail kit (12mm) for thermaline 85 units with backsplash, right PNC 913207
- U-clamping rail for back-to-back installations with backsplash PNC 913226
- INSERT.PROFILE,D850,TL-OTHER BRANDS PNC 913231
- - NOT TRANSLATED - PNC 913244
- SIDE PANEL TL85 WALL MOUNT. (L) H400 PNC 913632
- SIDE PANEL TL85 WALL MOUNT. (R) H400 PNC 913633
- SIDE PANEL TL85 WALLMOUNT(L) H400,FLUSHFIT PNC 913634
- SIDE PANEL TL85 WALL MOUNT. (R) H400,FL PNC 913635
- ADD. WALL MOUNT. FIXATION USA PNC 913640
- TL85/90 WALL MOUNTING KIT - TOP 400MM PNC 913648
- FILTER W=400MM PNC 913663
- ELECTRIC MAINSWITCH 25A 4mm² NM FOR MODULAR H800 ELECTRIC UNITS (FACTORY FITTED) PNC 913676

Recommended Detergents

- *NOT TRANSLATED* PNC 0S2292

Electric

- Supply voltage:** 400 V/3N ph/50/60 Hz
- Total Watts:** 5.1 kW

Key Information:

- Cooking Surface Depth:** 615 mm
- Cooking Surface Width:** 300 mm
- Working Temperature MIN:** 80 °C
- Working Temperature MAX:** 280 °C
- External dimensions, Width:** 400 mm
- External dimensions, Depth:** 850 mm
- External dimensions, Height:** 250 mm
- Net weight:** 69 kg
- Configuration:** One-Side Operated;Top
- Cooking surface type:**
- 588530 (MBHMBBDOAO)** Smooth
- 588534 (MBHNBBDOAO)** Ribbed
- Chromium Plated mild steel mirror
- Cooking surface - material:**

Sustainability

- Current consumption:** 7.4 Amps



Electrolux
PROFESSIONAL

**Modular Cooking Range Line
thermaline 85 - Half Module Electric
Fry Top, 1 Side with Backsplash**

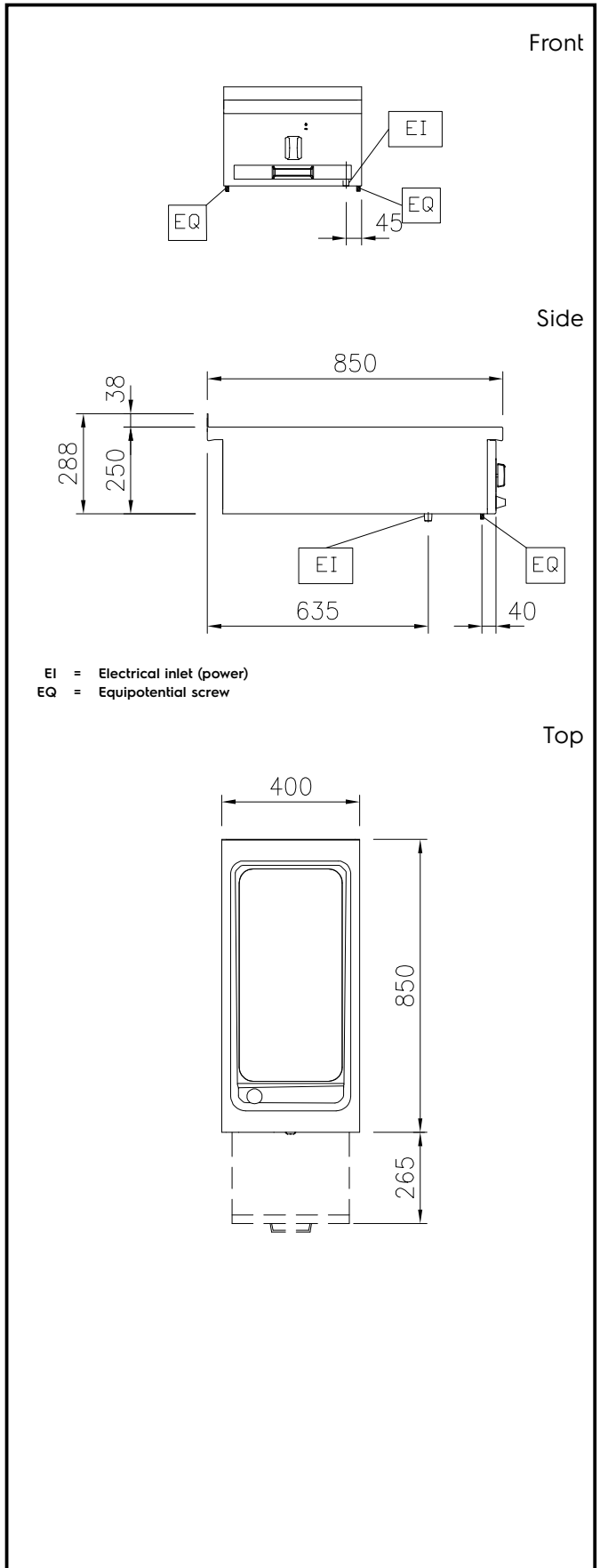
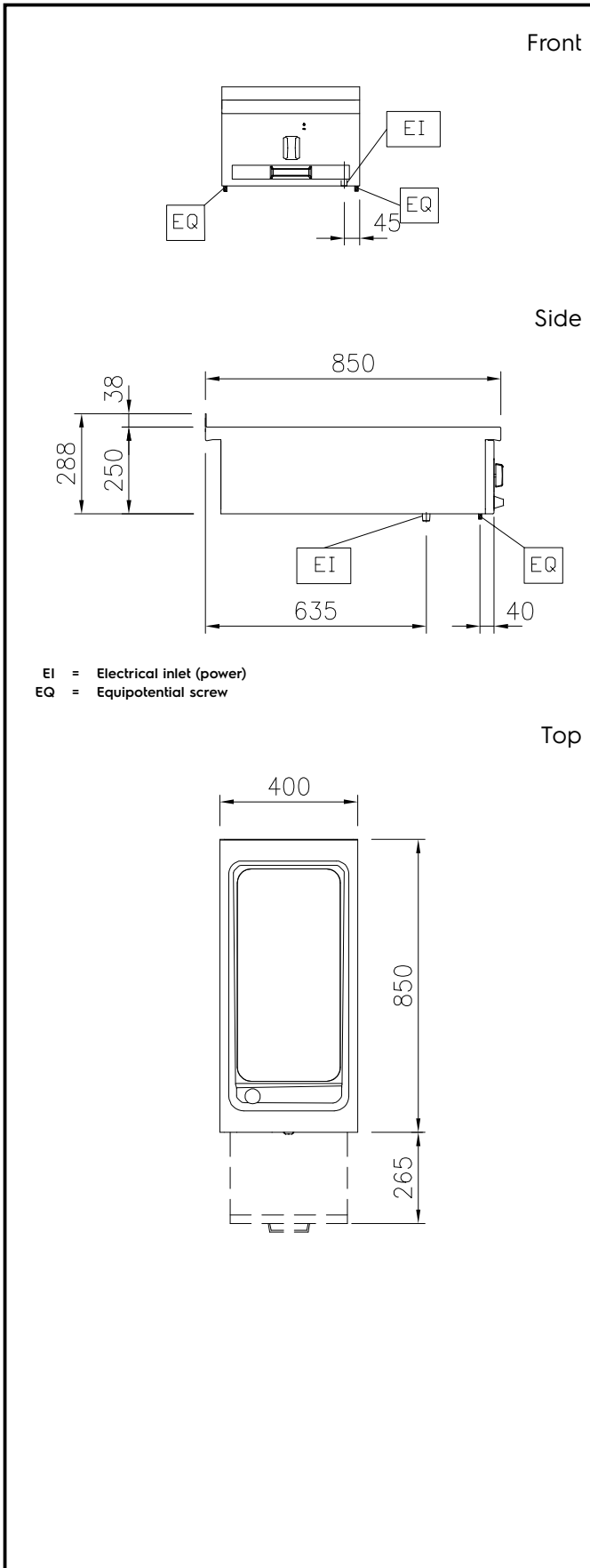

**Modular Cooking Range Line
thermaline 85 - Half Module Electric Fry Top, 1 Side with Backsplash**

The company reserves the right to make modifications to the products without prior notice. All information correct at time of printing.